

centerline

Simply designed. To be the best. **For you.**

2024 PRICE LIST
AUTHORIZED DEALERS ONLY
(EFFECTIVE JANUARY 1, 2024)

Table of Contents



Centerline™ by Traulsen Terms	3
Reach-Ins	4-6
Refrigerators & Freezers.....	4-5
Trayslide & Shelf Versatility Chart.....	6
Undercounter & Reach-In Blast Chillers.....	7-8
Undercounter Refrigerators & Freezers	9-12
Undercounter Refrigerators.....	10-11
Undercounter Freezers.....	12
Prep Tables.....	13-14
Centerline™ by Traulsen Accessory Kits	15-16
Centerline™ by Traulsen Model Number Nomenclature	17
Centerline™ by Traulsen Equipment Warranty.....	18-19

- To qualify for the 5 and 10-piece quantities, each order must contain a minimum of said quantities and products can be mixed and matched. Accessories do not count toward quantity levels.
Note: Only Centerline™ by Traulsen models can be mixed and matched to meet quantity thresholds.
- Split-shipments are allowed. Partial shipments are not allowed.
- Free freight applies to all serialized Centerline items purchased. Accessories purchased without a serialized item will be charged freight (see Traulsen’s Freight Policy for additional details).
- Free liftgate. 3-section units and oversized products with crated dimensions of 72" or more in length and/or 90" in height may be subject to liftgate fees.
- Standard Traulsen payment terms apply.
- Returns are not available for Centerline quantity buys of five (5) or more.
- All Centerline by Traulsen products are subject to the current Traulsen MAP policy.
- Redistribution of Centerline products is not allowed.

NOTE: Centerline branded equipment comprises a separate family of products and cannot be included as part of any Traulsen Dealer’s Choice programs.

If not specified above in the “Terms” section, refer to Traulsen Price List for General Information (Terms & Conditions of Sale, Return Goods Policy & Warranty Statement and Legal Terms & Conditions)

Centerline™ Price List is a CONFIDENTIAL DOCUMENT of ITW Food Equipment Group LLC, and is intended solely for the internal use of our authorized sales people, and as such it should not be redistributed or reproduced in any way without the express permission of Traulsen Marketing.



Terms & Conditions Apply
See Full Warranty Statement

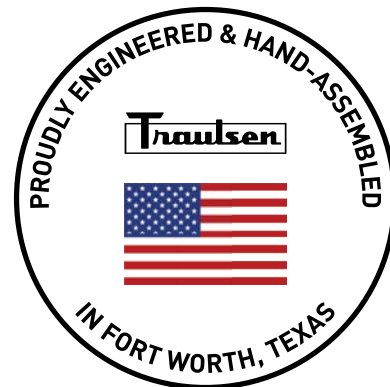



STANDARD FEATURES



QUALITY & PERFORMANCE

- + Balanced refrigeration system with oversized evaporator coil
- + Superior temperature maintenance and recovery
- + Capillary tube metering device (TXV on Freezers)



EASE OF USE

- + Electronic control with LED display for easy monitoring
- + Recessed handle(s) for easy operator grip
- + Stay-open / self-closing door(s) with locks
- + Ergonomically friendly, bottom-mounted system



DURABILITY

- + Easily accessible system for maintenance
- + Stainless steel front and sides with corrosion resistant anodized aluminum interior
- + Gasket protecting retainer



OPERATOR ASSURANCE

- + Durable construction for long equipment life
- + Environmentally friendly refrigerants
- + Extra storage space on top of unit
- + Six Year Parts & Labor Warranty
- + Seven Year Compressor Warranty

Solid & Glass Door* Models Available



*Glass Doors on Refrigerators only

Reach-Ins, Refrigerators & Freezers



CONFIGURATION	DEVICE CODE	LIST PRICE	MAP PRICE	QUANTITY DISCOUNTS		
				1 PC 50/10/25	5 PC 50/10/27	10 PC 50/10/29
Refrigerator – 1 Section, SOLID Door						
1 Sec Ref, half height solid doors, hinge left	CLBM-23R-HS-L	\$13,393	\$4,400	\$4,520	\$4,400	\$4,279
1 Sec Ref, half height solid doors, hinge right	CLBM-23R-HS-R	\$13,393	\$4,400	\$4,520	\$4,400	\$4,279
1 Sec Ref, full height solid door, hinge left	CLBM-23R-FS-L	\$12,006	\$3,944	\$4,052	\$3,944	\$3,836
1 Sec Ref, full height solid door, hinge right	CLBM-23R-FS-R	\$12,006	\$3,944	\$4,052	\$3,944	\$3,836
Refrigerator – 1 Section, GLASS Door						
1 Sec Ref, half height glass doors, hinge left	CLBM-23R-HG-L	\$14,461	\$4,750	\$4,881	\$4,750	\$4,620
1 Sec Ref, half height glass doors, hinge right	CLBM-23R-HG-R	\$14,461	\$4,750	\$4,881	\$4,750	\$4,620
1 Sec Ref, full height glass doors, hinge left	CLBM-23R-FG-L	\$13,719	\$4,507	\$4,630	\$4,507	\$4,383
1 Sec Ref, full height glass doors, hinge right	CLBM-23R-FG-R	\$13,719	\$4,507	\$4,630	\$4,507	\$4,383
Freezer – 1 Section, SOLID Door						
1 Sec Frz, half height solid doors, hinge left	CLBM-23F-HS-L	\$15,847	\$5,206	\$5,348	\$5,206	\$5,063
1 Sec Frz, half height solid doors, hinge right	CLBM-23F-HS-R	\$15,847	\$5,206	\$5,348	\$5,206	\$5,063
1 Sec Frz, full height solid doors, hinge left	CLBM-23F-FS-L	\$15,003	\$4,928	\$5,064	\$4,928	\$4,793
1 Sec Frz, full height solid doors, hinge right	CLBM-23F-FS-R	\$15,003	\$4,928	\$5,064	\$4,928	\$4,793
Refrigerator – 2 Section, SOLID Door						
2 Sec Ref, half height solid doors, hinge left/right	CLBM-49R-HS-LR	\$16,744	\$5,500	\$5,651	\$5,500	\$5,350
2 Sec Ref, half height solid doors, hinge left/left	CLBM-49R-HS-LL	\$16,744	\$5,500	\$5,651	\$5,500	\$5,350
2 Sec Ref, half height solid doors, hinge right/right	CLBM-49R-HS-RR	\$16,744	\$5,500	\$5,651	\$5,500	\$5,350
2 Sec Ref, full height solid doors, hinge left/right	CLBM-49R-FS-LR	\$15,594	\$5,123	\$5,263	\$5,123	\$4,982
2 Sec Ref, full height solid doors, hinge left/left	CLBM-49R-FS-LL	\$15,594	\$5,123	\$5,263	\$5,123	\$4,982
2 Sec Ref, full height solid doors, hinge right/right	CLBM-49R-FS-RR	\$15,594	\$5,123	\$5,263	\$5,123	\$4,982
Refrigerator – 2 Section, GLASS Door						
2 Sec Ref, half height glass doors, hinge left/right	CLBM-49R-HG-LR	\$19,149	\$6,290	\$6,463	\$6,290	\$6,118
2 Sec Ref, half height glass doors, hinge left/left	CLBM-49R-HG-LL	\$19,149	\$6,290	\$6,463	\$6,290	\$6,118
2 Sec Ref, half height glass doors, hinge right/right	CLBM-49R-HG-RR	\$19,149	\$6,290	\$6,463	\$6,290	\$6,118
2 Sec Ref, full height glass doors, hinge left/right	CLBM-49R-FG-LR	\$17,921	\$5,887	\$6,048	\$5,887	\$5,726
2 Sec Ref, full height glass doors, hinge left/left	CLBM-49R-FG-LL	\$17,921	\$5,887	\$6,048	\$5,887	\$5,726
2 Sec Ref, full height glass doors, hinge right/right	CLBM-49R-FG-RR	\$17,921	\$5,887	\$6,048	\$5,887	\$5,726
Freezer – 2 Section, SOLID Door						
2 Sec Frz, half height solid doors, hinge left/right	CLBM-49F-HS-LR	\$22,305	\$7,327	\$7,528	\$7,327	\$7,126
2 Sec Frz, half height solid doors, hinge left/left	CLBM-49F-HS-LL	\$22,305	\$7,327	\$7,528	\$7,327	\$7,126
2 Sec Frz, half height solid doors, hinge right/right	CLBM-49F-HS-RR	\$22,305	\$7,327	\$7,528	\$7,327	\$7,126
2 Sec Frz, full height solid doors, hinge left/right	CLBM-49F-FS-LR	\$21,040	\$6,912	\$7,101	\$6,912	\$6,722
2 Sec Frz, full height solid doors, hinge left/left	CLBM-49F-FS-LL	\$21,040	\$6,912	\$7,101	\$6,912	\$6,722
2 Sec Frz, full height solid doors, hinge right/right	CLBM-49F-FS-RR	\$21,040	\$6,912	\$7,101	\$6,912	\$6,722

Reach-Ins, Refrigerators & Freezers

Trayslide & Shelf Versatility Chart

TRAYSLIDES

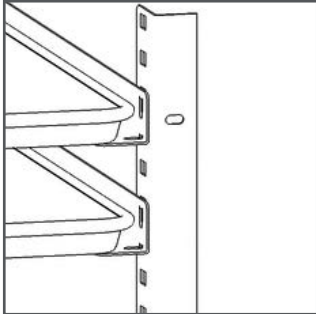

#1 Trayslides
Standard

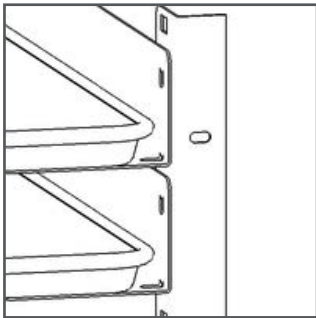

Universal Trayslides
Standard

TRAYSLIDES

DESCRIPTION	SPACING			
	2"	3"	4"	5"
#1 Trayslides – Standard				
16 ga. stainless steel angle type for bottom support of: (1) 18" x 26" Pan				
Behind full height door – all models	26	17	13	10
Behind upper half height door – all models	12	8	6	4
Behind lower half height door – all models	12	8	6	5

DESCRIPTION	SPACING		
	4"	5"	6"
Universal Trayslides – Standard			
16 ga. stainless steel angle type for bottom support of: (1) 18" x 26" Pan or (2) 12" x 20" Pans			
Behind full height door – all models	13	10	8
Behind upper half height door – all models	6	4	4
Behind lower half height door – all models	6	5	4

SHELVES

CAPACITY	STD.	MAX.
	Behind full height door mounted on standard shelf pins	3
Behind half height door mounted on standard shelf pins	3	7
Behind full height door mounted on optional pilasters	3	12 (4" spacing)
Behind half height door mounted on optional pilasters	3	11 (4" spacing)

NOTES:

1. For all after market parts call Traulsen parts department at 800-825-8220.
2. The above quantities represent the maximum amount of trayslides recommended by Traulsen to achieve best air circulation and refrigeration performance.
3. Optional trayslides are not available for Compact Undercounter, and Prep Table models.
4. All Centerline™ by Traulsen accessory kits are pre-packaged for easy installation at the job site.



STANDARD FEATURES



QUALITY & PERFORMANCE

- + High performance refrigeration system
- + Thermostatic expansion valve metering device
- + Superior temperature maintenance
- + Quickly chill hot food to below 41°F in 90 minutes*

*Chill times will vary depending on product type, quantity, and container used.



EASE OF USE

- + Digital control designed for easy operation
- + Recessed handle for easy operator grip
- + Stay-open/self-closing door



DURABILITY

- + Stainless steel front, sides, door & interior
- + Easily accessible system for maintenance
- + 2³/₈" thick high-density insulation



OPERATOR ASSURANCE

- + Food probe for accurate temperature readings
- + Soft or hard chill mode options
- + Durable construction for long equipment life
- + Six year parts & labor warranty
- + Seven year compressor warranty

Reach-In, Undercounter & Undercounter Worktop Models Available



Undercounter & Reach-In Blast Chillers



CONFIGURATION	DEVICE CODE	LIST PRICE	MAP PRICE	QUANTITY DISCOUNTS		
				1 PC 50/10/25	5 PC 50/10/27	10 PC 50/10/29
Reach-In Blast Chillers						
(7) 18" x 26" or (14) 12" x 20" Pan capacity, hinge left	CLBC7-L	\$43,460	\$14,277	\$14,668	\$14,277	\$13,885
(7) 18" x 26" or (14) 12" x 20" Pan capacity, hinge right	CLBC7-R	\$43,460	\$14,277	\$14,668	\$14,277	\$13,885
Undercounter Blast Chillers						
(4) 18" x 26" or (8) 12" x 20" Pan capacity, hinge left	CLBC4-L	\$38,690	\$12,710	\$13,058	\$12,710	\$12,361
(4) 18" x 26" or (8) 12" x 20" Pan capacity, hinge right	CLBC4-R	\$38,690	\$12,710	\$13,058	\$12,710	\$12,361
(4) 18" x 26" or (8) 12" x 20" Pan capacity, worktop, hinge left	CLBC4-WT-L	\$39,644	\$13,023	\$13,380	\$13,023	\$12,666
(4) 18" x 26" or (8) 12" x 20" Pan capacity, worktop, hinge right	CLBC4-WT-R	\$39,644	\$13,023	\$13,380	\$13,023	\$12,666



STANDARD FEATURES

QUALITY & PERFORMANCE

- + Superior temperature maintenance and recovery
- + Capillary tube metering device

EASE OF USE

- + Stay-open / self-closing door(s) for ease of loading and unloading
- + Two epoxy-coated shelves per door on pilasters (door models)
- + Electronic control with easy to read LED display
- + Recessed handle provides easy grip
- + Door rehinge feature on all sizes for flexibility

SANITATION AND CLEANING

- + Stainless steel exterior with corrosion resistant anodized aluminum interior
- + Fully removable drawers (on drawer models)

OPERATOR ASSURANCE

- + Durable construction for long equipment life
- + Environmentally friendly refrigerants
- + Worktop models available
- + Six Year Parts & Labor Warranty
- + Seven Year Compressor Warranty

Solid Door, Glass Door* & Drawer Models Available



*Glass Doors on Refrigerators only



Some models are ENERGY STAR® listed. Please refer to energystar.gov to view the most up-to-date product listing and performance data for ENERGY STAR® listed products.

Undercounter Refrigerators



CONFIGURATION	DEVICE CODE	LIST PRICE	MAP PRICE	QUANTITY DISCOUNTS		
				1 PC 50/10/25	5 PC 50/10/27	10 PC 50/10/29
Undercounter Refrigerators						
27" Undercounter Ref, solid door, hinge left	CLUC-27R-SD-L	\$7,184	\$2,360	\$2,425	\$2,360	\$2,295
27" Undercounter Ref, solid door, hinge right	CLUC-27R-SD-R	\$7,184	\$2,360	\$2,425	\$2,360	\$2,295
27" Undercounter Ref, glass door, hinge left	CLUC-27R-GD-L	\$8,723	\$2,866	\$2,944	\$2,866	\$2,787
27" Undercounter Ref, glass door, hinge right	CLUC-27R-GD-R	\$8,723	\$2,866	\$2,944	\$2,866	\$2,787
27" Undercounter Ref, 2 drawers, (1) full size pan per drawer	CLUC-27R-DW	\$10,728	\$3,524	\$3,621	\$3,524	\$3,428
36" Undercounter Ref, solid doors, hinge left/right	CLUC-36R-SD-LR	\$9,654	\$3,171	\$3,258	\$3,171	\$3,084
36" Undercounter Ref, solid doors, hinge left/left	CLUC-36R-SD-LL	\$9,654	\$3,171	\$3,258	\$3,171	\$3,084
36" Undercounter Ref, solid doors, hinge right/right	CLUC-36R-SD-RR	\$9,654	\$3,171	\$3,258	\$3,171	\$3,084
36" Undercounter Ref, glass doors, hinge left/right	CLUC-36R-GD-LR	\$10,391	\$3,413	\$3,507	\$3,413	\$3,320
36" Undercounter Ref, glass doors, hinge left/left	CLUC-36R-GD-LL	\$10,391	\$3,413	\$3,507	\$3,413	\$3,320
36" Undercounter Ref, glass doors, hinge right/right	CLUC-36R-GD-RR	\$10,391	\$3,413	\$3,507	\$3,413	\$3,320
48" Undercounter Ref, solid doors, hinge left/right	CLUC-48R-SD-LR	\$10,789	\$3,544	\$3,641	\$3,544	\$3,447
48" Undercounter Ref, solid doors, hinge left/left	CLUC-48R-SD-LL	\$10,789	\$3,544	\$3,641	\$3,544	\$3,447
48" Undercounter Ref, solid doors, hinge right/right	CLUC-48R-SD-RR	\$10,789	\$3,544	\$3,641	\$3,544	\$3,447
48" Undercounter Ref, glass doors, hinge left/right	CLUC-48R-GD-LR	\$13,016	\$4,276	\$4,393	\$4,276	\$4,159
48" Undercounter Ref, glass doors, hinge left/left	CLUC-48R-GD-LL	\$13,016	\$4,276	\$4,393	\$4,276	\$4,159
48" Undercounter Ref, glass doors, hinge right/right	CLUC-48R-GD-RR	\$13,016	\$4,276	\$4,393	\$4,276	\$4,159
48" Undercounter Ref, 4 drawers, (1) 1/2 pan & (1) 1/3 pan per drawer	CLUC-48R-DW	\$17,878	\$5,873	\$6,034	\$5,873	\$5,712
60" Undercounter Ref, solid doors, hinge left/right	CLUC-60R-SD-LR	\$11,977	\$3,934	\$4,042	\$3,934	\$3,827
60" Undercounter Ref, solid doors, hinge left/left	CLUC-60R-SD-LL	\$11,977	\$3,934	\$4,042	\$3,934	\$3,827
60" Undercounter Ref, solid doors, hinge right/right	CLUC-60R-SD-RR	\$11,977	\$3,934	\$4,042	\$3,934	\$3,827
60" Undercounter Ref, glass doors, hinge left/right	CLUC-60R-GD-LR	\$13,120	\$4,310	\$4,428	\$4,310	\$4,192
60" Undercounter Ref, glass doors, hinge left/left	CLUC-60R-GD-LL	\$13,120	\$4,310	\$4,428	\$4,310	\$4,192
60" Undercounter Ref, glass doors, hinge right/right	CLUC-60R-GD-RR	\$13,120	\$4,310	\$4,428	\$4,310	\$4,192
60" Undercounter Ref, 4 drawers, (1) full size pan per drawer	CLUC-60R-DW	\$18,106	\$5,948	\$6,111	\$5,948	\$5,785
72" Undercounter Ref, solid doors, hinge left/right/right	CLUC-72R-SD-LRR	\$13,720	\$4,507	\$4,631	\$4,507	\$4,384
72" Undercounter Ref, solid doors, hinge left/left/left	CLUC-72R-SD-LLL	\$13,720	\$4,507	\$4,631	\$4,507	\$4,384
72" Undercounter Ref, solid doors, hinge right/right/right	CLUC-72R-SD-RRR	\$13,720	\$4,507	\$4,631	\$4,507	\$4,384
72" Undercounter Ref, glass doors, hinge left/right/right	CLUC-72R-GD-LRR	\$14,468	\$4,753	\$4,883	\$4,753	\$4,623
72" Undercounter Ref, glass doors, hinge left/left/left	CLUC-72R-GD-LLL	\$14,468	\$4,753	\$4,883	\$4,753	\$4,623
72" Undercounter Ref, glass doors, hinge right/right/right	CLUC-72R-GD-RRR	\$14,468	\$4,753	\$4,883	\$4,753	\$4,623
72" Undercounter Ref, 6 drawers, (1) 1/2 pan & (1) 1/3 pan per drawer	CLUC-72R-DW	\$21,586	\$7,091	\$7,285	\$7,091	\$6,897

Undercounter Refrigerators

CONFIGURATION	DEVICE CODE	LIST PRICE	MAP PRICE	QUANTITY DISCOUNTS		
				1 PC 50/10/25	5 PC 50/10/27	10 PC 50/10/29
Undercounter Worktop Refrigerators						
27" Undercounter Ref, solid door, worktop, hinge left	CLUC-27R-SD-WTL	\$7,395	\$2,429	\$2,496	\$2,429	\$2,363
27" Undercounter Ref, solid door, worktop, hinge right	CLUC-27R-SD-WTR	\$7,395	\$2,429	\$2,496	\$2,429	\$2,363
27" Undercounter Ref, glass door, worktop, hinge left	CLUC-27R-GD-WTL	\$9,033	\$2,967	\$3,049	\$2,967	\$2,886
27" Undercounter Ref, glass door, worktop, hinge right	CLUC-27R-GD-WTR	\$9,033	\$2,967	\$3,049	\$2,967	\$2,886
27" Undercounter Ref, worktop, 2 drawers, (1) full size pan per drawer	CLUC-27R-DW-WT	\$10,937	\$3,593	\$3,691	\$3,593	\$3,494
36" Undercounter Ref, solid doors, worktop, hinge left/right	CLUC-36R-SD-WTLR	\$10,173	\$3,342	\$3,433	\$3,342	\$3,250
36" Undercounter Ref, solid doors, worktop, hinge left/left	CLUC-36R-SD-WTLL	\$10,173	\$3,342	\$3,433	\$3,342	\$3,250
36" Undercounter Ref, solid doors, worktop, hinge right/right	CLUC-36R-SD-WTRR	\$10,173	\$3,342	\$3,433	\$3,342	\$3,250
36" Undercounter Ref, glass doors, worktop, hinge left/right	CLUC-36R-GD-WTLR	\$12,410	\$4,077	\$4,188	\$4,077	\$3,965
36" Undercounter Ref, glass doors, worktop, hinge left/left	CLUC-36R-GD-WTLL	\$12,410	\$4,077	\$4,188	\$4,077	\$3,965
36" Undercounter Ref, glass doors, worktop, hinge right/right	CLUC-36R-GD-WTRR	\$12,410	\$4,077	\$4,188	\$4,077	\$3,965
48" Undercounter Ref, solid doors, worktop, hinge left/right	CLUC-48R-SD-WTLR	\$11,091	\$3,643	\$3,743	\$3,643	\$3,544
48" Undercounter Ref, solid doors, worktop, hinge left/left	CLUC-48R-SD-WTLL	\$11,091	\$3,643	\$3,743	\$3,643	\$3,544
48" Undercounter Ref, solid doors, worktop, hinge right/right	CLUC-48R-SD-WTRR	\$11,091	\$3,643	\$3,743	\$3,643	\$3,544
48" Undercounter Ref, glass doors, worktop, hinge left/right	CLUC-48R-GD-WTLR	\$13,406	\$4,404	\$4,525	\$4,404	\$4,283
48" Undercounter Ref, glass doors, worktop, hinge left/left	CLUC-48R-GD-WTLL	\$13,406	\$4,404	\$4,525	\$4,404	\$4,283
48" Undercounter Ref, glass doors, worktop, hinge right/right	CLUC-48R-GD-WTRR	\$13,406	\$4,404	\$4,525	\$4,404	\$4,283
48" Undercounter Ref, worktop, 4 drawers, (1) 1/2 pan & (1) 1/3 pan per drawer	CLUC-48R-DW-WT	\$18,180	\$5,972	\$6,136	\$5,972	\$5,809
60" Undercounter Ref, solid doors, worktop, hinge left/right	CLUC-60R-SD-WTLR	\$12,312	\$4,044	\$4,155	\$4,044	\$3,934
60" Undercounter Ref, solid doors, worktop, hinge left/left	CLUC-60R-SD-WTLL	\$12,312	\$4,044	\$4,155	\$4,044	\$3,934
60" Undercounter Ref, solid doors, worktop, hinge right/right	CLUC-60R-SD-WTRR	\$12,312	\$4,044	\$4,155	\$4,044	\$3,934
60" Undercounter Ref, glass doors, worktop, hinge left/right	CLUC-60R-GD-WTLR	\$14,200	\$4,665	\$4,793	\$4,665	\$4,537
60" Undercounter Ref, glass doors, worktop, hinge left/left	CLUC-60R-GD-WTLL	\$14,200	\$4,665	\$4,793	\$4,665	\$4,537
60" Undercounter Ref, glass doors, worktop, hinge right/right	CLUC-60R-GD-WTRR	\$14,200	\$4,665	\$4,793	\$4,665	\$4,537
60" Undercounter Ref, worktop, 4 drawers, (1) full size pan per drawer	CLUC-60R-DW-WT	\$19,397	\$6,372	\$6,546	\$6,372	\$6,197
72" Undercounter Ref, solid doors, worktop, hinge left/right/right	CLUC-72R-SD-WTLRR	\$14,118	\$4,638	\$4,765	\$4,638	\$4,511
72" Undercounter Ref, solid doors, worktop, hinge left/left/left	CLUC-72R-SD-WTLLL	\$14,118	\$4,638	\$4,765	\$4,638	\$4,511
72" Undercounter Ref, solid doors, worktop, hinge right/right/right	CLUC-72R-SD-WTRRR	\$14,118	\$4,638	\$4,765	\$4,638	\$4,511
72" Undercounter Ref, glass doors, worktop, hinge left/right/right	CLUC-72R-GD-WTLRR	\$14,845	\$4,877	\$5,010	\$4,877	\$4,743
72" Undercounter Ref, glass doors, worktop, hinge left/left/left	CLUC-72R-GD-WTLLL	\$14,845	\$4,877	\$5,010	\$4,877	\$4,743
72" Undercounter Ref, glass doors, worktop, hinge right/right/right	CLUC-72R-GD-WTRRR	\$14,845	\$4,877	\$5,010	\$4,877	\$4,743
72" Undercounter Ref, worktop, 6 drawers, (1) 1/2 pan & (1) 1/3 pan per drawer	CLUC-72R-DW-WT	\$24,355	\$8,001	\$8,220	\$8,001	\$7,781

Undercounter Freezers



CONFIGURATION	DEVICE CODE	LIST PRICE	MAP PRICE	QUANTITY DISCOUNTS		
				1 PC 50/10/25	5 PC 50/10/27	10 PC 50/10/29
Undercounter Freezers						
27" Undercounter Frz, solid door, hinge left	CLUC-27F-SD-L	\$8,644	\$2,840	\$2,917	\$2,840	\$2,762
27" Undercounter Frz, solid door, hinge right	CLUC-27F-SD-R	\$8,644	\$2,840	\$2,917	\$2,840	\$2,762
27" Undercounter Frz, 2 drawers, (1) full size pan per drawer	CLUC-27F-DW	\$12,222	\$4,015	\$4,125	\$4,015	\$3,905
36" Undercounter Frz, solid doors, hinge left/right	CLUC-36F-SD-LR	\$11,074	\$3,638	\$3,737	\$3,638	\$3,538
36" Undercounter Frz, solid doors, hinge left/left	CLUC-36F-SD-LL	\$11,074	\$3,638	\$3,737	\$3,638	\$3,538
36" Undercounter Frz, solid doors, hinge right/right	CLUC-36F-SD-RR	\$11,074	\$3,638	\$3,737	\$3,638	\$3,538
48" Undercounter Frz, solid doors, hinge left/right	CLUC-48F-SD-LR	\$12,190	\$4,004	\$4,114	\$4,004	\$3,895
48" Undercounter Frz, solid doors, hinge left/left	CLUC-48F-SD-LL	\$12,190	\$4,004	\$4,114	\$4,004	\$3,895
48" Undercounter Frz, solid doors, hinge right/right	CLUC-48F-SD-RR	\$12,190	\$4,004	\$4,114	\$4,004	\$3,895
48" Undercounter Frz, 4 drawers, (1) 1/2 pan & (1) 1/3 pan per drawer	CLUC-48F-DW	\$19,697	\$6,470	\$6,648	\$6,470	\$6,293
60" Undercounter Frz, solid doors, hinge left/right	CLUC-60F-SD-LR	\$15,562	\$5,112	\$5,252	\$5,112	\$4,972
60" Undercounter Frz, solid doors, hinge left/left	CLUC-60F-SD-LL	\$15,562	\$5,112	\$5,252	\$5,112	\$4,972
60" Undercounter Frz, solid doors, hinge right/right	CLUC-60F-SD-RR	\$15,562	\$5,112	\$5,252	\$5,112	\$4,972
60" Undercounter Frz, 4 drawers, (1) full size pan per drawer	CLUC-60F-DW	\$19,194	\$6,305	\$6,478	\$6,305	\$6,132
72" Undercounter Frz, solid doors, hinge left/right/right	CLUC-72F-SD-LRR	\$17,896	\$5,879	\$6,040	\$5,879	\$5,718
72" Undercounter Frz, solid doors, hinge left/left/left	CLUC-72F-SD-LLL	\$17,896	\$5,879	\$6,040	\$5,879	\$5,718
72" Undercounter Frz, solid doors, hinge right/right/right	CLUC-72F-SD-RRR	\$17,896	\$5,879	\$6,040	\$5,879	\$5,718
Undercounter Worktop Freezers						
27" Undercounter Frz, solid door, worktop, hinge left	CLUC-27F-SD-WTL	\$8,680	\$2,851	\$2,930	\$2,851	\$2,773
27" Undercounter Frz, solid door, worktop, hinge right	CLUC-27F-SD-WTR	\$8,680	\$2,851	\$2,930	\$2,851	\$2,773
27" Undercounter Frz, 2 drawers, worktop, (1) full size pan per drawer	CLUC-27F-DW-WT	\$12,504	\$4,108	\$4,220	\$4,108	\$3,995
36" Undercounter Frz, solid doors, worktop, hinge left/right	CLUC-36F-SD-WTLR	\$11,356	\$3,730	\$3,833	\$3,730	\$3,628
36" Undercounter Frz, solid doors, worktop, hinge left/left	CLUC-36F-SD-WTLL	\$11,356	\$3,730	\$3,833	\$3,730	\$3,628
36" Undercounter Frz, solid doors, worktop, hinge right/right	CLUC-36F-SD-WTRR	\$11,356	\$3,730	\$3,833	\$3,730	\$3,628
48" Undercounter Frz, solid doors, worktop, hinge left/right	CLUC-48F-SD-WTLR	\$12,832	\$4,215	\$4,331	\$4,215	\$4,100
48" Undercounter Frz, solid doors, worktop, hinge left/left	CLUC-48F-SD-WTLL	\$12,832	\$4,215	\$4,331	\$4,215	\$4,100
48" Undercounter Frz, solid doors, worktop, hinge right/right	CLUC-48F-SD-WTRR	\$12,832	\$4,215	\$4,331	\$4,215	\$4,100
48" Undercounter Frz, 4 drawers, worktop (1) 1/2 pan & (1) 1/3 pan per drawer	CLUC-48F-DW-WT	\$20,156	\$6,621	\$6,803	\$6,621	\$6,440
60" Undercounter Frz, solid doors, worktop, hinge left/right	CLUC-60F-SD-WTLR	\$15,906	\$5,225	\$5,368	\$5,225	\$5,082
60" Undercounter Frz, solid doors, worktop, hinge left/left	CLUC-60F-SD-WTLL	\$15,906	\$5,225	\$5,368	\$5,225	\$5,082
60" Undercounter Frz, solid doors, worktop, hinge right/right	CLUC-60F-SD-WTRR	\$15,906	\$5,225	\$5,368	\$5,225	\$5,082
60" Undercounter Frz, 4 drawers, worktop, (1) full size pan per drawer	CLUC-60F-DW-WT	\$19,635	\$6,450	\$6,627	\$6,450	\$6,273
72" Undercounter Frz, solid doors, worktop, hinge left/right/right	CLUC-72F-SD-WTLRR	\$18,292	\$6,009	\$6,174	\$6,009	\$5,844
72" Undercounter Frz, solid doors, worktop, hinge left/left/left	CLUC-72F-SD-WTLLL	\$18,292	\$6,009	\$6,174	\$6,009	\$5,844
72" Undercounter Frz, solid doors, worktop, hinge right/right/right	CLUC-72F-SD-WTRRR	\$18,292	\$6,009	\$6,174	\$6,009	\$5,844



STANDARD FEATURES

★ QUALITY & PERFORMANCE

- + Superior temperature maintenance and recovery
- + Capillary tube metering device
- + NSF 7 rated for use with 6" deep pans

👉 EASE OF USE

- + Stay-open / self-closing door(s) for ease of loading and unloading
- + Two epoxy-coated shelves per door on pilasters (door models)
- + Electronic control with easy to read LED display
- + Recessed handle provides easy grip
- + Door rehinge feature on all sizes for flexibility

+💧 SANITATION AND CLEANING

- + Removable, easy to clean cutting board
- + Stainless steel exterior with corrosion resistant anodized aluminum interior
- + Isolated pan rail keeps ingredients from falling into bottom section
- + Fully removable drawers (on drawer models)

☑ OPERATOR ASSURANCE

- + Meets NSF7 performance testing for open top refrigerated food prep units
- + Insulated roll top lid helps extend the life of product when not in use
- + Mega Top options for more storage capacity
- + Six Year Parts & Labor Warranty
- + Seven Year Compressor Warranty

Solid Door & Drawer Models Available



Prep Tables

CONFIGURATION	DEVICE CODE	LIST PRICE	MAP PRICE	QUANTITY DISCOUNTS		
				1 PC 50/10/25	5 PC 50/10/27	10 PC 50/10/29
Prep Tables						
27" Prep table, 8 pan, solid door, hinge left	CLPT-2708-SD-L	\$8,260	\$2,713	\$2,788	\$2,713	\$2,639
27" Prep table, 8 pan, solid door, hinge right	CLPT-2708-SD-R	\$8,260	\$2,713	\$2,788	\$2,713	\$2,639
27" Prep table, 8 pan, 2 drawers	CLPT-2708-DW	\$11,802	\$3,877	\$3,983	\$3,877	\$3,771
36" Prep table, 10 pan, solid doors, hinge left/right	CLPT-3610-SD-LR	\$11,168	\$3,669	\$3,769	\$3,669	\$3,568
36" Prep table, 10 pan, solid doors, hinge left/left	CLPT-3610-SD-LL	\$11,168	\$3,669	\$3,769	\$3,669	\$3,568
36" Prep table, 10 pan, solid doors, hinge right/right	CLPT-3610-SD-RR	\$11,168	\$3,669	\$3,769	\$3,669	\$3,568
48" Prep table, 12 pan, solid doors, hinge left/right	CLPT-4812-SD-LR	\$12,720	\$4,179	\$4,293	\$4,179	\$4,064
48" Prep table, 12 pan, solid doors, hinge left/left	CLPT-4812-SD-LL	\$12,720	\$4,179	\$4,293	\$4,179	\$4,064
48" Prep table, 12 pan, solid doors, hinge right/right	CLPT-4812-SD-RR	\$12,720	\$4,179	\$4,293	\$4,179	\$4,064
48" Prep table, 12 pan, 4 drawers	CLPT-4812-DW	\$19,807	\$6,507	\$6,685	\$6,507	\$6,328
60" Prep table, 16 pan, solid doors, hinge left/right	CLPT-6016-SD-LR	\$13,547	\$4,450	\$4,572	\$4,450	\$4,328
60" Prep table, 16 pan, solid doors, hinge left/left	CLPT-6016-SD-LL	\$13,547	\$4,450	\$4,572	\$4,450	\$4,328
60" Prep table, 16 pan, solid doors, hinge right/right	CLPT-6016-SD-RR	\$13,547	\$4,450	\$4,572	\$4,450	\$4,328
60" Prep table, 16 pan, 4 drawers	CLPT-6016-DW	\$20,639	\$6,780	\$6,966	\$6,780	\$6,594
72" Prep table, 20 pan, solid doors, hinge left/right/right	CLPT-7220-SD-LRR	\$15,344	\$5,041	\$5,179	\$5,041	\$4,902
72" Prep table, 20 pan, solid doors, hinge left/left/left	CLPT-7220-SD-LLL	\$15,344	\$5,041	\$5,179	\$5,041	\$4,902
72" Prep table, 20 pan, solid doors, hinge right/right/right	CLPT-7220-SD-RRR	\$15,344	\$5,041	\$5,179	\$5,041	\$4,902
72" Prep table, 20 pan, 6 drawers	CLPT-7220-DW	\$23,322	\$7,661	\$7,871	\$7,661	\$7,451
Mega Top Prep Tables						
27" Prep table, 12 pan, solid door, Mega Top, hinge left	CLPT-2712-SD-L	\$9,875	\$3,244	\$3,333	\$3,244	\$3,155
27" Prep table, 12 pan, solid door, Mega Top, hinge right	CLPT-2712-SD-R	\$9,875	\$3,244	\$3,333	\$3,244	\$3,155
27" Prep table, 12 pan, 2 drawers, Mega Top	CLPT-2712-DW	\$13,279	\$4,362	\$4,482	\$4,362	\$4,243
36" Prep table, 15 pan, solid doors, Mega Top, hinge left/right	CLPT-3615-SD-LR	\$12,590	\$4,136	\$4,249	\$4,136	\$4,023
36" Prep table, 15 pan, solid doors, Mega Top, hinge left/left	CLPT-3615-SD-LL	\$12,590	\$4,136	\$4,249	\$4,136	\$4,023
36" Prep table, 15 pan, solid doors, Mega Top, hinge right/right	CLPT-3615-SD-RR	\$12,590	\$4,136	\$4,249	\$4,136	\$4,023
48" Prep table, 18 pan, solid doors, Mega Top, hinge left/right	CLPT-4818-SD-LR	\$14,118	\$4,638	\$4,765	\$4,638	\$4,511
48" Prep table, 18 pan, solid doors, Mega Top, hinge left/left	CLPT-4818-SD-LL	\$14,118	\$4,638	\$4,765	\$4,638	\$4,511
48" Prep table, 18 pan, solid doors, Mega Top, hinge right/right	CLPT-4818-SD-RR	\$14,118	\$4,638	\$4,765	\$4,638	\$4,511
48" Prep table, 18 pan, 4 drawers, Mega Top	CLPT-4818-DW	\$21,569	\$7,085	\$7,280	\$7,085	\$6,891
60" Prep table, 24 pan, solid doors, Mega Top, hinge left/right	CLPT-6024-SD-LR	\$16,975	\$5,576	\$5,729	\$5,576	\$5,424
60" Prep table, 24 pan, solid doors, Mega Top, hinge left/left	CLPT-6024-SD-LL	\$16,975	\$5,576	\$5,729	\$5,576	\$5,424
60" Prep table, 24 pan, solid doors, Mega Top, hinge right/right	CLPT-6024-SD-RR	\$16,975	\$5,576	\$5,729	\$5,576	\$5,424
60" Prep table, 24 pan, 4 drawers, Mega Top	CLPT-6024-DW	\$22,729	\$7,466	\$7,671	\$7,466	\$7,262
72" Prep table, 30 pan, solid doors, Mega Top, hinge left/right/right	CLPT-7230-SD-LRR	\$18,439	\$6,057	\$6,223	\$6,057	\$5,891
72" Prep table, 30 pan, solid doors, Mega Top, hinge left/left/left	CLPT-7230-SD-LLL	\$18,439	\$6,057	\$6,223	\$6,057	\$5,891
72" Prep table, 30 pan, solid doors, Mega Top, hinge right/right/right	CLPT-7230-SD-RRR	\$18,439	\$6,057	\$6,223	\$6,057	\$5,891
72" Prep table, 30 pan, 6 drawers, Mega Top	CLPT-7230-DW	\$26,909	\$8,840	\$9,082	\$8,840	\$8,597

Each kit includes all necessary mounting hardware except where noted. All Centerline accessory kits are pre-packaged for easy installation at the job site.

CLBM REACH-IN ACCESSORY KITS

DESCRIPTION	DEVICE CODE	LIST PRICE	MAP PRICE	QUANTITY DISCOUNTS		
				1 PC 50/10/25	5 PC 50/10/27	10 PC 50/10/29
1 Section						
(1) epoxy coated shelf on pins	CLBMACC-1SHLF1	\$98	\$32	\$33	\$32	\$31
(3) epoxy coated shelves on pins	CLBMACC-3SHLF1	\$294	\$97	\$99	\$97	\$94
(7) pairs universal trayslides (supports not included)	CLBMACC-7TSU	\$669	\$220	\$226	\$220	\$214
Pilaster kit For #1 trayslides (supports not included)	CLBMACC-PLSTR11	\$886	\$291	\$299	\$291	\$283
(4) pairs 1" trayslides (supports not included)	CLBMACC-4TS1	\$160	\$53	\$54	\$53	\$51
(1) pair #1 trayslides (supports not included)	CLBMACC-1TS1	\$50	\$16	\$17	\$16	\$16
(1) pair universal trayslides (supports not included)	CLBMACC-1TSU	\$120	\$39	\$41	\$39	\$38
Pilaster kit for universal trayslides (supports not included)	CLBMACC-PLSTRU1	\$490	\$161	\$165	\$161	\$157
(7) pairs universal trayslides with supports	CLBMACC-7TSUKT1	\$1,168	\$384	\$394	\$384	\$373
(8) pairs #1 trayslides with supports	CLBMACC-8TS1KT1	\$964	\$317	\$325	\$317	\$308
2 Section						
(1) epoxy coated shelf on pins	CLBMACC-1SHLF2	\$81	\$27	\$27	\$27	\$26
(3) epoxy coated shelves on pins	CLBMACC-3SHLF2	\$244	\$80	\$82	\$80	\$78
Pilaster kit for #1 trayslides (supports not included)	CLBMACC-PLSTR12	\$1,367	\$449	\$461	\$449	\$437
(1) pair #1 trayslides (supports not included)	CLBMACC-1TS1	\$50	\$16	\$17	\$16	\$16
(4) pairs 1" trayslides (supports not included)	CLBMACC-4TS1	\$160	\$53	\$54	\$53	\$51
(1) pair universal trayslides (supports not included)	CLBMACC-1TSU	\$120	\$39	\$41	\$39	\$38
(7) pairs universal trayslides (supports not included)	CLBMACC-7TSU	\$669	\$220	\$226	\$220	\$214
Pilaster kit for universal trayslides (supports not included)	CLBMACC-PLSTRU2	\$190	\$62	\$64	\$62	\$61
(7) pairs universal trayslides with supports	CLBMACC-7TSUKT2	\$1,168	\$384	\$394	\$384	\$373
(8) pairs #1 trayslides with supports	CLBMACC-8TS1KT2	\$1,445	\$475	\$488	\$475	\$462
Supports						
6" stem casters, set of 4	CLBMACC-46CASTER	\$161	\$53	\$54	\$53	\$51
6" legs, adjustable, set of 4	CLBMACC-46LEGS	\$129	\$42	\$44	\$42	\$41
4" stem casters, set of 4	CLBMACC-44CASTER	\$127	\$42	\$43	\$42	\$41

CLUC UNDERCOUNTER & CLPT PREP TABLE ACCESSORY KITS

DESCRIPTION	DEVICE CODE	LIST PRICE	MAP PRICE	QUANTITY DISCOUNTS		
				1 PC 50/10/25	5 PC 50/10/27	10 PC 50/10/29
Set of (4) 2-3/4" stem casters	CLUCACC-42CASTER	\$281	\$92	\$95	\$92	\$90
Set of (6) 2-3/4" stem casters	CLUCACC-62CASTER	\$422	\$139	\$142	\$139	\$135
Set of (6) 4" stem casters	CLUCACC-64CASTER	\$190	\$62	\$64	\$62	\$61
Set of (4) 6" stem casters	CLUCACC-46CASTER	\$161	\$53	\$54	\$53	\$51
Set of (6) 6" stem casters	CLUCACC-66CASTER	\$241	\$79	\$81	\$79	\$77
Set of (4) 4" stem casters	CLUCACC-44CASTERS	\$127	\$42	\$43	\$42	\$41
Set of (4) 6" stem adjustable legs	CLUCACC-46LEGS	\$99	\$33	\$33	\$33	\$32
Set of (6) 6" stem adjustable legs	CLUCACC-66LEGS	\$145	\$48	\$49	\$48	\$46
27" backsplash kit	CLUCACC-27BCKSP	\$59	\$19	\$20	\$19	\$19
36" backsplash kit	CLUCACC-36BCKSP	\$81	\$27	\$27	\$27	\$26
48" backsplash kit	CLUCACC-48BCKSP	\$123	\$40	\$42	\$40	\$39
60" backsplash kit	CLUCACC-60BCKSP	\$129	\$42	\$44	\$42	\$41
72" backsplash kit	CLUCACC-72BCKSP	\$162	\$53	\$55	\$53	\$52
Set of (2) 27" shelves	CLUCACC-27SHELF	\$219	\$72	\$74	\$72	\$70
Set of (2) 36" shelves LH	CLUCACC-36SHLFLH	\$195	\$64	\$66	\$64	\$62
Set of (2) 36" shelves RH	CLUCACC-36SHLFRH	\$195	\$64	\$66	\$64	\$62
Set of (2) 48"/72" shelves LH	CLUCACC-47SHLFLH	\$214	\$70	\$72	\$70	\$68
Set of (2) 48"/72" shelves RH	CLUCACC-47SHLFRH	\$214	\$70	\$72	\$70	\$68
Set of (2) 60" shelves LH	CLUCACC-60SHLFLH	\$225	\$74	\$76	\$74	\$72
Set of (2) 60" shelves RH	CLUCACC-60SHLFRH	\$225	\$74	\$76	\$74	\$72
Set of (2) 72" shelves center	CLUCACC-72SHLFACT	\$232	\$76	\$78	\$76	\$74

CLBC BLAST CHILLER ACCESSORY KITS

DESCRIPTION	DEVICE CODE	LIST PRICE	MAP PRICE	QUANTITY DISCOUNTS		
				1 PC 50/10/25	5 PC 50/10/27	10 PC 50/10/29
Set of (4) 6" casters	CLBCACC-46CASTER	\$245	\$80	\$83	\$80	\$78
Set of (4) 6" adjustable legs	CLBCACC-4LEGS	\$626	\$206	\$211	\$206	\$200

Model Number Nomenclature

CENTERLINE™ REACH-INS

CL	BM-	23	R-	FS-	L
POSITION (1) SERIES CL Centerline™	POSITION (2) SYSTEM LOCATION/TYPE BM Bottom Mounted Self-Contained	POSITION (3) CABINET WIDTH (SECTIONS) 23 23" (1-section) 49 49" (2-section)	POSITION (4) TYPE OF CABINET R Refrigerator F Freezer	POSITION (5) TYPE OF DOOR(S) FS Full-Height Solid HS Half-Height Solid FG Full-Height Hinged Glass HG Half-Height Hinged Glass	POSITION (6) HINGING L Left R Right LR Left/Right LL Left/Left RR Right/Right

CENTERLINE™ COMPACTS

CL	UC-	27	R-	SD-	L
POSITION (1) SERIES CL Centerline™	POSITION (2) TYPE OF CABINET UC Undercounter	POSITION (3) CABINET WIDTH 27 27" 36 36" 48 48" 60 60" 72 72"	POSITION (4) TYPE OF CABINET R Refrigerator F R Freezer	POSITION (5) TYPE OF DOOR(S) SD Solid Door(s) GD Glass Door(s) DW Drawers	POSITION (6) HINGING L Left R Right LR Left/Right LL Left/Left RR Right/Right LRR Left/Right/Right RRR Right/Right/Right LLL Left/Left/Left WT If WT is present, the UC is a Worktop

CENTERLINE™ PREP TABLES

CL	PT-	27	12-	SD-	L
POSITION (1) SERIES CL Centerline™	POSITION (2) TYPE OF CABINET PT Prep Table	POSITION (3) CABINET WIDTH 27 27" 36 36" 48 48" 60 60" 72 72"	POSITION (4) NUMBER OF PANS 8 8 Pans 10 10 Pans 12 12 Pans 15 15 Pans 16 16 Pans 18 18 Pans 20 20 Pans 24 24 Pans 30 30 Pans	POSITION (5) TYPE OF DOOR(S) SD Solid Door(s) DW Drawers	POSITION (6) HINGING L Left R Right LR Left/Right LL Left/Left RR Right/Right LRR Left/Right/Right RRR Right/Right/Right LLL Left/Left/Left

CENTERLINE™ BLAST CHILLERS

CL	BC	7-	L
POSITION (1) SERIES CL Centerline™	POSITION (2) TYPE OF CABINET BC Blast Chiller	POSITION (3) REACH-IN/UNDERCOUNTER & NO. OF SHEET PANS 7 Reach-In, (7) 18" x 26" Sheet Pans 4 Undercounter, (4) 18" x 26" Sheet Pans	POSITION (4) HINGING L Left R Right WT If WT is present, the Undercounter is a Worktop

U.S. DOMESTIC WARRANTY



Terms & Conditions Apply
See Full Warranty Statement

SIX-YEAR PARTS AND LABOR WARRANTY

FEG Refrigeration, a division of ITW Food Equipment Group LLC d/b/a Traulsen (“Traulsen”) warrants to the original end-user (the “Owner”) of the Equipment (as defined below) that Traulsen will convey the Equipment free and clear of all liens, security interests, and encumbrances created by, through or under Traulsen. Traulsen further warrants to the Owner that for a period of six (6) years from the later of either (a) the date of delivery to the common carrier or (b) the date of original installation (the “Domestic Warranty Period”) (provided that in no event shall the Domestic Warranty Period commence later than 3 months from the date of delivery to the common carrier by Traulsen unless otherwise agreed upon by the parties in writing), under normal use and given proper installation and maintenance as determined by Traulsen, the Equipment: (a) will conform to the written specifications as provided by Traulsen (“Specifications”) and (b) will be free from substantial defects in material and workmanship. “Equipment” means serialized units of refrigeration equipment sold by Traulsen and branded as “Traulsen”, “Kairak” or “Centerline by Traulsen”. “Equipment” does not include, Air Curtains, equipment for export, spare parts, component parts, replacement parts, service parts, products not branded as Traulsen, Kairak or Centerline by Traulsen, products sold by Traulsen that are expressly subject to a different warranty and/or warranty period, and other products whose product documentation reference a different warranty policy and/or exclude this warranty policy (collectively, the “Excluded Products”).

SEVEN-YEAR COMPRESSOR WARRANTY

The warranty period for compressors (the “Compressor Warranty Period”) shall extend for an additional one (1) year beyond the Domestic Warranty Period. In the case of a nonconforming compressor, Traulsen shall provide a single replacement compressor; however, all installation, recharging, and repair costs shall be the responsibility of the Owner. For Equipment purchased for use with a condenser provided by a third-party, the six-year parts and labor warranty will apply only to those components contained within the Equipment to the point of connection of the refrigeration lines leading to the third-party condenser.

LIFETIME CAM-LIFT HINGE AND WORKFLOW HANDLE WARRANTY

Traulsen warrants to the Owner for the life of the Equipment (the “Cam-Lift Lifetime Warranty Period”) that the housing of cam-lift hinges and workflow handles will be free from substantial defects. In the case of non-conforming housing for cam-lift hinge or workflow handle during the Cam-Lift Lifetime Warranty Period, Traulsen shall provide a replacement part; however, Owner shall be responsible for any other replacement costs, including but not limited to, installation and labor.

WHAT IS NOT COVERED BY THIS WARRANTY

Traulsen’s responsibility under this warranty is subject to the additional limits below:

- **No Consequential Damages.** Traulsen is not liable for loss of product or loss of profit, or any special, indirect, or consequential damages including, but not limited to, loss or damage resulting from the loss of product, whether or not due to refrigeration failure and whether or not Traulsen has been notified of the possibility of such damages.
- **Consumable Components or Ordinary Wear Items.** This Warranty excludes all consumable components and ordinary wear items within the Equipment, such as but not limited to components that are removable without the use of tools, gaskets, shelf pins, and light bulbs. All Excluded Products sold separately are also excluded.
- **Non-OEM parts.** Any use of non-OEM parts or parts not supplied by Traulsen or specified by Traulsen in the Operator’s Manual on the Traulsen website (such as but not limited to EZ Clean gaskets, sensors, controls, etc.) shall automatically void this Warranty with respect to such parts and any damage, defect or wear caused by such parts.
- **Specified Causes.** This Warranty does not cover any damage, defect or wear resulting from fire, water, burglary, accident, abuse, misuse, lack of preventive maintenance, transit, acts of God, terrorism, power surges, improper installation, or repairs or installation by unqualified third parties, or improper modifications outside published parameters or modifications implemented outside of the direction of Traulsen tech support. All warranty claims made outside of the Domestic Warranty Period, Compressor Warranty Period or Cam-Lift Lifetime Warranty Period, as applicable, are expressly excluded from this Warranty.
- **Specified Uses.** The Equipment is intended only for commercial use in conditioned spaces and shall not be used by residences, consumers, or households or in any non-commercial application or in any non-conditioned spaces. This Warranty does not apply to, and shall not cover, any Equipment that is installed or used in any way in any residential, consumer or non-commercial application. No warranties, express or implied, are provided to any residential, consumer or non-commercial purchaser or owner of the Equipment.
- **Owner’s Use.** The Owner is solely responsible for determining if Equipment is fit for a particular purpose and suitable for Owner’s application. Accordingly, and due to the nature and manner of the Equipment, Traulsen is not responsible for the results or consequences of any use, misuse, or application of its Equipment.

U.S. DOMESTIC WARRANTY (continued)

SOLE REMEDIES

In the event of a breach of the warranties set forth above, Traulsen will, at Traulsen's option, and as Owner's sole and exclusive remedy and Traulsen's sole and exclusive obligation, repair (including labor costs), refund or replace any nonconforming Equipment, provided that:

- Traulsen is promptly notified during the Domestic Warranty Period, Compressor Warranty Period or Cam-Lift Lifetime Warranty Period, as applicable, in writing upon discovery of the nonconformance with a detailed explanation of any alleged deficiencies;
- Traulsen is given a reasonable opportunity to investigate all claims;
- Traulsen's examination of any alleged defective part confirms such alleged deficiencies and that the deficiencies were not caused by misuse, neglect improper installation, improper repair, improper alteration or improper testing; AND
- In the case of a nonconforming part, Owner must return the part to Traulsen within 30 days from the date of repair. Failure to return a claimed defective part to Traulsen within the 30 days will waive the right to the warranty claim.

THIS DOMESTIC WARRANTY SETS FORTH THE EXTENT OF TRAUlsen'S LIABILITY FOR SALES WITHIN THE UNITED STATES. NO EQUIPMENT MAY BE RETURNED TO TRAUlsen WITHOUT TRAUlsen'S PRIOR WRITTEN APPROVAL. EXCEPT AS EXPRESSLY SET FORTH ABOVE IN THIS WARRANTY STATEMENT, TRAUlsen MAKES NO WARRANTY OR REPRESENTATION OF ANY KIND, EXPRESS OR IMPLIED (INCLUDING NO WARRANTY OF MERCHANTABILITY OR FITNESS FOR ANY PARTICULAR PURPOSE). IN NO EVENT WILL TRAUlsen'S LIABILITY IN CONNECTION WITH THIS WARRANTY OR THE SALE OF THE EQUIPMENT EXCEED THE PURCHASE PRICE OF THE EQUIPMENT AS TO WHICH THE CLAIM IS MADE.

This warranty only applies to units shipped from Traulsen's manufacturing facilities on or after January 1, 2023.

To report a warranty claim, please email service@traulsen.com or call [1.800.825.8220](tel:1.800.825.8220) and include the serial and model number of the affected unit. All service for warranty claims must be dispatched by Traulsen. Traulsen reserves the right to refuse warranty claims for warranty service conducted by unauthorized third-party providers.

EXPORT WARRANTY

For sales of Traulsen refrigeration equipment ("Equipment") outside of the United States, Traulsen warrants to the original purchaser of the Equipment ("Purchaser") that Traulsen will convey the Equipment free and clear of all liens, security interests and encumbrances created by, through or under Traulsen. Traulsen further warrants that for a period of one (1) year from the date of delivery to the common carrier (the "Export Warranty Period") unless otherwise agreed upon by the parties in writing, under normal use and given proper installation and maintenance as determined by Traulsen, the Equipment: (a) will conform to the Specifications as provided by Traulsen; and (b) will be free from substantial defects in material and workmanship. It is the end user's responsibility to arrange for the export shipping.

The Export Warranty does not apply to: (a) consumable components or ordinary wear items; (b) components that are removable without the use of tools including but not limited to gaskets, shelf pins, and light bulbs; (c) use of the Equipment components or parts not supplied by Traulsen or specified in the Operator's Manual as set forth on Traulsen's website; or (d) damage resulting from fire, water, burglary, accident, abuse, misuse, transit, acts of God, terrorism, power surges, improper installation, or repairs or installation by unauthorized third parties. Additionally, the Equipment is intended only for commercial use and should not be used by consumers or households or in any non-commercial application. This Export Warranty does not apply to, and shall not cover, any Equipment that is installed or used in any way in any residential or non-commercial application. No warranties, express or implied, are provided to any residential, consumer or non-commercial purchaser or owner of the Equipment.

For Traulsen units purchased with a condenser provided by a third-party other than Traulsen, this standard warranty will apply only to those components contained within the unit to the point of connection of the refrigeration lines leading to the to the third-party condenser.

In the event of a breach of the warranties set forth above (the "Export Warranty"), Traulsen will, at Traulsen's option and as Purchaser's sole remedy, refund or replace any non-conforming Equipment, but not including labor, freight, export costs, packaging costs or any other costs beyond the replacement part, component or product, provided that (a) during the Export Warranty Period Traulsen is promptly notified in writing upon discovery of such nonconformance with a detailed explanation of any alleged deficiencies; (b) Traulsen is given a reasonable opportunity to investigate all claims; and (c) Traulsen's examination of such piece of Equipment defective part confirms the alleged nonconformity and that the nonconformities were not caused by misuse, neglect, improper installation, unauthorized alteration or repair or improper testing. Traulsen reserves the right to, at its request, require Purchaser shall ship the alleged defective part to Traulsen for inspection and confirmation of defect. No Equipment may be returned without Traulsen's approval.

Purchaser is solely responsible for determining if Equipment is fit for a particular purpose and suitable for Purchaser's application. Accordingly and due to the nature and manner of Traulsen's Equipment, Traulsen is not responsible for the results or consequences of use, misuse, or application of its Equipment.

THIS EXPORT WARRANTY SETS FORTH THE EXTENT OF TRAUlsen'S LIABILITY FOR SALES OUTSIDE THE UNITED STATES. EXCEPT AS SET FORTH ABOVE, TRAUlsen MAKES NO WARRANTY OR REPRESENTATION OF ANY KIND, EXPRESS OR IMPLIED (INCLUDING NO WARRANTY OF MERCHANTABILITY OR FITNESS FOR ANY PARTICULAR PURPOSE). IN NO EVENT WILL TRAUlsen'S LIABILITY IN CONNECTION WITH THE AGREEMENT OR SALE OF THE EQUIPMENT EXCEED THE PURCHASE PRICE OF THE EQUIPMENT AS TO WHICH THE CLAIM IS MADE. IN NO EVENT SHALL TRAUlsen BE LIABLE FOR ANY LOSS OF USE, LOSS OF PRODUCT, LOSS OF PROFIT, OR ANY OTHER INDIRECT, INCIDENTAL, SPECIAL, OR CONSEQUENTIAL DAMAGES RESULTING FROM THIS WARRANTY EVEN IF TRAUlsen HAS BEEN NOTIFIED OF THE POSSIBILITY OF SUCH DAMAGES.

Table of Contents



Centerline™ by Hobart Terms.....	21
Mixers.....	22-23
HMM10.....	22
HMM20.....	23
Slicers.....	24-26
EDGE10.....	24
EDGE12.....	24
EDGE13.....	25
EDGE14.....	25
EDGE13A.....	26
CUH/CUL Undercounter Dishmachine.....	27-28
CDH/CDL Door-Type Dishmachine.....	29-30

- To qualify for the 5 and 10-piece quantities, each order must contain a minimum of said quantities and products can be mixed and matched. Accessories do not count toward quantity levels.
Note: Only Centerline™ by Hobart models can be mixed and matched to meet quantity thresholds.
- **Centerline Program Rebate:** Dealer will receive a 5% functional rebate on net billings for a minimum quantity of 5 or more pieces on a single order.
- Split shipments are allowed. Partial shipments are not allowed.
- Free freight applies to all serialized Centerline items purchased. Accessories purchased without a serialized item will be charged freight (see Hobart's Freight Policy for additional details).
- Free liftgate. Oversized products with crated dimensions of 72" or more in length and/or 90" or more in height may be subject to liftgate fees.
- Standard Hobart payment terms apply.
- Returns are not available for Centerline quantity buys of five (5) or more.
- All Centerline by Hobart products are subject to the current Hobart MAP policy.
- Redistribution of Centerline products is not allowed.

NOTE: Centerline branded equipment comprises a separate family of products and cannot be included as part of any Hobart Dealer's Choice programs.

If not specified above in the "Terms" section, refer to Hobart Price List for General Information (Terms & Conditions of Sale, Return Goods Policy & Warranty Statement and Legal Terms & Conditions)

STANDARD FEATURES

CONSISTENT MIXING PERFORMANCE

- + All gear transmission
- + 3 fixed speeds
- + 3/4 HP heavy duty motor – the power needed to mix a variety of items

SANITATION & CLEANING

- + Stainless steel removable bowl guard – makes clean up easy and thorough
- + Clean and contemporary DuoTone finish

EASE OF USE

- + Bayonet style agitators – easy to remove and operate
- + Digital timer with Last Time Remind – remembers the last time set, makes mixing multiple batches a snap!
- + Ergonomic bowl lift with EZ Grip handle – smoothly moves the bowl into mixing position

OPERATOR ASSURANCE

- + Triple interlock system – bowl in place and raised, bowl guard closed
- + GearSafe™ technology – protects system gears from shearing if speeds are changed while in operation



DEVICE DESCRIPTION	DEVICE CODE	LIST PRICE	MAP PRICE	QUANTITY DISCOUNTS		
				1 PIECE PRICE	5 PIECE PRICE	10 PIECE PRICE
Bench mixer in 120/60/1 voltage with gear transmission, 3/4 HP motor with 3-speed controls. 10 qt. stainless steel bowl, bayonet style wire whip, flat beater and dough hook included	HMM10-1STD	\$2,600.00	\$1,900.00	\$1,820.00	\$1,748.00	\$1,672.00

Mixer Accessories

DEVICE DESCRIPTION	DEVICE CODE	LIST PRICE	MAP PRICE	QUANTITY DISCOUNTS		
				1 PIECE PRICE	5 PIECE PRICE	10 PIECE PRICE
Flat Beater	BEATER-HMM10	\$110.00	\$110.00	\$77.00	\$70.00	\$65.00
Stainless Steel Bowl	BOWL-HMM10	\$200.00	\$150.00	\$140.00	\$130.00	\$120.00
Dough Hook	DOUGH-HMM10	\$110.00	\$110.00	\$77.00	\$70.00	\$65.00
Wire Whip	WHIP-HMM10	\$110.00	\$110.00	\$77.00	\$70.00	\$65.00

STANDARD FEATURES

CONSISTENT MIXING PERFORMANCE

- + All gear transmission
- + 3 fixed speeds
- + 1/2 HP heavy duty motor – the power needed to mix a variety of items

SANITATION & CLEANING

- + Stainless steel removable bowl guard – makes clean up easy and thorough
- + Clean and contemporary DuoTone finish

EASE OF USE

- + Bayonet style agitators – easy to remove and operate
- + Digital timer with Last Time Remind – remembers the last time set, makes mixing multiple batches a snap!
- + Ergonomic bowl lift with EZ Grip handle – lift and lower the bowl with ease

OPERATOR ASSURANCE

- + Triple interlock system – bowl in place and raised, bowl guard closed
- + GearSafe™ technology – protects system gears from shearing if speeds are changed while in operation



DEVICE DESCRIPTION	DEVICE CODE	LIST PRICE	MAP PRICE	QUANTITY DISCOUNTS		
				1 PIECE PRICE	5 PIECE PRICE	10 PIECE PRICE
Bench mixer in 100-120/50/60/1 voltage with gear transmission, 1/2 HP motor with 3-speed controls. 20 qt. stainless steel bowl, bayonet style wire whip, flat beater and dough hook included	HMM20-1STD	\$4,917.00	\$3,748.00	\$3,442.00	\$3,013.00	\$2,791.00

Mixer Accessories

DEVICE DESCRIPTION	DEVICE CODE	LIST PRICE	MAP PRICE	QUANTITY DISCOUNTS		
				1 PIECE PRICE	5 PIECE PRICE	10 PIECE PRICE
Flat Beater	BEATER-HMM20	\$270.00	\$230.00	\$189.00	\$162.00	\$150.00
Stainless Steel Bowl	BOWL-HMM20	\$407.00	\$347.00	\$285.00	\$242.00	\$228.00
Ingredient Chute	CHUTE-HMM20	\$118.00	\$102.00	\$83.00	\$70.00	\$66.00
Dough Hook	DOUGH-HMM20	\$270.00	\$230.00	\$189.00	\$162.00	\$150.00
J Hook	JDOUGH-HMM20	\$597.00	\$508.00	\$418.00	\$353.00	\$331.00
Wire Whip	WHIP-HMM20	\$419.00	\$357.00	\$293.00	\$246.00	\$235.00

EDGE10 Slicer

STANDARD FEATURES

PERFORMANCE

- + 10" chrome-plated carbon steel knife
- + 1/3 HP motor
- + Hobart poly-v belt drive system

SANITATION & CLEANING

- + Anodized aluminum base
- + Removable carriage
- + Removable meat grip assembly
- + Removable product deflector

EASE OF USE

- + Double sided meat grip and slide rod
- + Top-mounted sharpener with ceramic stone – sharpen and hone in one step

OPERATOR ASSURANCE

- + No-volt release
- + Gauge plate interlock
- + Permanently mounted ring guard



DEVICE DESCRIPTION	DEVICE CODE	LIST PRICE	MAP PRICE	QUANTITY DISCOUNTS		
				1 PIECE PRICE	5 PIECE PRICE	10 PIECE PRICE
Manual Slicer with 10" chrome-plated carbon steel knife	EDGE10-11	\$1,898.00	\$1,499.00	\$1,329.00	\$1,231.00	\$1,195.00

EDGE12 Slicer

STANDARD FEATURES

PERFORMANCE

- + 12" chrome-plated carbon steel knife
- + 1/2 HP motor
- + Hobart poly-v belt drive system

SANITATION & CLEANING

- + Anodized aluminum base
- + Removable carriage
- + Removable meat grip assembly
- + Removable product deflector

EASE OF USE

- + Double sided meat grip and slide rod
- + Top-mounted sharpener with ceramic stone – sharpen and hone in one step

OPERATOR ASSURANCE

- + No-volt release
- + Gauge plate interlock
- + Permanently mounted ring guard



DEVICE DESCRIPTION	DEVICE CODE	LIST PRICE	MAP PRICE	QUANTITY DISCOUNTS		
				1 PIECE PRICE	5 PIECE PRICE	10 PIECE PRICE
Manual Slicer with 12" chrome-plated carbon steel knife	EDGE12-11	\$2,526.00	\$1,948.00	\$1,768.00	\$1,727.00	\$1,687.00

EDGE13 Slicer

STANDARD FEATURES

PERFORMANCE

- + 13" chrome-plated carbon steel knife
- + 1/2 HP motor
- + Hobart poly-v belt drive system

SANITATION & CLEANING

- + Anodized aluminum base
- + Removable carriage
- + Removable meat grip assembly
- + Removable product deflector

EASE OF USE

- + Double sided meat grip and slide rod
- + Top-mounted sharpener with ceramic stone – sharpen and hone in one step

OPERATOR ASSURANCE

- + No-volt release
- + Carriage interlock
- + Gauge-plate interlock



DEVICE DESCRIPTION	DEVICE CODE	LIST PRICE	MAP PRICE	QUANTITY DISCOUNTS		
				1 PIECE PRICE	5 PIECE PRICE	10 PIECE PRICE
Manual Slicer with 13" chrome-plated carbon steel knife	EDGE13-11	\$3,008.00	\$2,116.00	\$2,106.00	\$1,815.00	\$1,689.00

EDGE14 Slicer

STANDARD FEATURES

PERFORMANCE

- + 14" chrome-plated carbon steel knife
- + 1/2 HP motor
- + Hobart poly-v belt drive system

SANITATION & CLEANING

- + Anodized aluminum base
- + Removable carriage
- + Removable meat grip assembly
- + Removable product deflector

EASE OF USE

- + Double sided meat grip and slide rod
- + Top-mounted sharpener with ceramic stone – sharpen and hone in one step

OPERATOR ASSURANCE

- + No-volt release
- + Gauge plate interlock



DEVICE DESCRIPTION	DEVICE CODE	LIST PRICE	MAP PRICE	QUANTITY DISCOUNTS		
				1 PIECE PRICE	5 PIECE PRICE	10 PIECE PRICE
Manual Slicer with 14" chrome-plated carbon steel knife	EDGE14-11	\$4,050.00	\$2,893.00	\$2,835.00	\$2,546.00	\$2,494.00

EDGE13A Automatic Slicer

STANDARD FEATURES

PERFORMANCE

- + 13" chrome-plated carbon steel knife
- + 1/2 HP heavy duty motor
- + Hobart poly-v belt drive system
- + Manual and automatic option

SANITATION & CLEANING

- + Anodized aluminum base
- + Removable carriage
- + Removable meat grip assembly
- + Removable product deflector

EASE OF USE

- + Double sided meat grip and slide rod
- + Top-mounted sharpener with ceramic stone – sharpen and hone in one step

OPERATOR ASSURANCE

- + No-volt release
- + Carriage interlock
- + Gauge-plate interlock



DEVICE DESCRIPTION	DEVICE CODE	LIST PRICE	MAP PRICE	QUANTITY DISCOUNTS		
				1 PIECE PRICE	5 PIECE PRICE	10 PIECE PRICE
Manual and Automatic Slicer with 13" chrome-plated carbon steel knife	EDGE13A-11	\$6,976.00	\$5,213.00	\$4,883.00	\$4,040.00	\$3,809.00

CUH/CUL Undercounter Dishmachine



STANDARD FEATURES



SIMPLE TO OPERATE & MAINTAIN

- + One-touch activation for standard wash, or press twice for extended wash cycle
- + Angled control display
- + Optional stand for height enhances operator comfort and productivity
- + Easily monitor wash and rinse temperatures
- + Delime notification alerts the operator when it's time for this important preventative maintenance routine



SUSTAINABILITY

- + Wash capacity of 24 racks/hour, with just .84 gallons of rinse water per rack



QUALITY & PERFORMANCE

- + Soft start slowly builds wash pressure to protect fragile ware items
- + The perfect size for tableware – the dishes you wash the most
- + Low-profile, revolving upper and lower arms provide full rack coverage



OPERATOR ASSURANCE

- + Sense-A-Temp™ booster ensures 180°F final rinse temperature
Note: *CUH only.*
- + Optional chemical sensing indicator senses and signals operators when it's time to replace chemical bottles
Note: *Chemical sanitizer sensing indicator is standard on CUL. Additional sensing indicators for detergent and rinse aid are ordered as an accessory.*



DEVICE DESCRIPTION	DEVICE CODE	LIST PRICE	MAP PRICE	QUANTITY DISCOUNTS		
				1 PIECE PRICE	5 PIECE PRICE	10 PIECE PRICE
High Temp Sanitizing, 208-240/60/1	CUH-1	\$6,850.00	\$5,131.00	\$4,795.00	\$4,483.00	\$4,349.00
Chemical Sanitizing, 120/60/1	CUL-1	\$6,850.00	\$5,131.00	\$4,795.00	\$4,483.00	\$4,349.00

Undercounter Dishwasher Accessories

DEVICE DESCRIPTION	DEVICE CODE	LIST PRICE	MAP PRICE	QUANTITY DISCOUNTS		
				1 PIECE PRICE	5 PIECE PRICE	10 PIECE PRICE
Stainless Steel Wash/Rinse Arm Assembly – includes (2), 1 set for top and 1 set for bottom	ARMSET-CUSST	\$431.00	\$323.00	\$301.70	\$279.00	\$267.00
Chemical Sensing Indicators – includes (2) indicator displays for rinse aid and detergent	CHEMSENSORS-CU	\$215.00	\$161.00	\$150.50	\$140.00	\$133.00
Drain Water Tempering Kit	DWT-CUH	\$418.00	\$313.00	\$292.60	\$279.00	\$272.00
Leg Stand with Rack Storage	STAND-CU44CM	\$473.00	\$354.00	\$331.10	\$317.00	\$313.00
Power Cord Kit (CUH) <i>NEMA 6-30, 208-240 Volt, 30-Amp, 1 PH</i>	PWRCORD-30A240V1P	\$418.00	\$313.00	\$292.60	\$279.00	\$275.00
Power Cord Kit (CUL) <i>NEMA 5-20P, 120 Volt, 20-Amp, 1 PH</i>	CORD-PWRKIT-CHLX	\$285.00	\$199.50	\$199.50	\$165.00	\$162.00
External Height Adjustable Casters – Machine width increases by 4.25", height is adjustable by +0-1"	EXTERN-CASTER-CU	\$435.00	\$326.00	\$304.50	\$280.00	\$272.00
Internal Height Adjustable Casters – Machine width is not affected; height will increase by +3-3.75"	STANDARD-CAST-CU	\$1,717.00	\$1,286.00	\$1,201.90	\$1,105.00	\$1,072.00
Stand – 6" leg extension	STAND-6INCH-CU	\$897.00	\$691.00	\$627.90	\$600.00	\$592.00



CDH



CDL

STANDARD FEATURES



SIMPLE TO OPERATE & MAINTAIN

Top mounted digital display

- + Simple to use and easy to see with normal & extended cycle options

Pumped drain

- + Provides installation flexibility

3-phase single point connection standard

- + Field convertible to single phase (CDH model only)



SUSTAINABILITY

4-sided door

- + Retains heat and saves energy

Recirculating design

- + Saves a significant amount of water over fill & dump machines



QUALITY & PERFORMANCE

Hot water sanitizing with a pumped rinse

- + Eliminates issues relating to facility water pressure (CDH model only)

51 racks per hour at .86 (CDL) & .73 (CDH) gallons per rack

- + High throughput efficient design

18" pillarless opening

- + Is easy to load and can accommodate a single sheet pan



OPERATOR ASSURANCE

Chemical sanitizing with built-in chemical pumps

- + Gives flexibility for chemical provider (CDL model only)

Onboard Sense-A-Temp™ booster

- + Ensures 180°F final rinse temperature (CDH model only)

DEVICE DESCRIPTION	DEVICE CODE	LIST PRICE	MAP PRICE	QUANTITY DISCOUNTS		
				1 PIECE PRICE	5 PIECE PRICE	10 PIECE PRICE
High Temp Sanitizing, 208-240/60/3	CDH-1	\$13,527.00	\$10,132.00	\$9,468.90	\$9,024.00	\$8,645.00
Chemical Sanitizing, 120/60/1	CDL-1	\$6,685.00	\$5,007.00	\$4,679.50	\$4,488.00	\$4,286.00

Door-Type Dishwasher Accessories

DEVICE DESCRIPTION	DEVICE CODE	LIST PRICE	MAP PRICE	QUANTITY DISCOUNTS		
				1 PIECE PRICE	5 PIECE PRICE	10 PIECE PRICE
Chemical pump for CDH – Internal pump with indicator for detergent and rinse aid	CHEMPUMP-CDH	\$942.00	\$706.00	\$659.40	\$633.00	\$582.00
Chemical Sensing Indicator – includes (2) indicator displays for rinse aid and detergent – display for sanitizer (1 in kit)	CHEMSENSORS-CDL	\$135.00	\$101.00	\$94.50	\$91.00	\$84.00
Splash shield and sheet pan adaptor – For corner installation	CORNER-INST-CD	\$563.00	\$422.00	\$394.10	\$378.00	\$348.00
Flanged Feet: Bolt down or weld down	FLNG-FT-CD	\$806.00	\$604.00	\$564.20	\$542.00	\$499.00
Pressure Regulating Valve for CDH – 3/4" for incoming pressure above 65psi	PRESREG-3/40BR@A	\$382.00	\$267.40	\$267.40	\$257.00	\$235.00
Pressure Regulating Valve – 3/4" brass pressure regulator for PSI>25 for CDL	PRESREG-3/40BR	\$382.00	\$267.40	\$267.40	\$257.00	\$235.00
Pumped drain air gap kit	PUMPDRN-AIRGAP	\$237.00	\$165.90	\$165.90	\$159.00	\$145.00
Water Hammer Arrestor – Includes 3/4" regulator, gauge, shock arrestor and garden hose adapter	WTRHAMARREST-AM16	\$817.00	\$571.90	\$571.90	\$549.00	\$502.00
Drain water tempering kit	DWT-AM16	\$1,306.00	\$914.20	\$914.20	\$878.00	\$802.00
Chem Relay Kit – For use with external chemical systems provided by others	CHEM-RELAY-CD	\$259.00	\$199.00	\$181.30	\$173.00	\$171.00



701 S. Ridge Avenue
Troy, Ohio 45373

Simply designed. To be the best. **For you.**

888-4HOBART (888-446-2278)
centerlinefoodequipment.com



4401 Blue Mound Road
Fort Worth, TX 76106